



Cat[®] 310

MINI HYDRAULIC EXCAVATOR

FEATURES:

The Cat[®] 310 Mini Excavator delivers maximum power and performance in a mini size to help you work in a wide range of applications.

ALL DAY COMFORT

- A sealed and pressurized cab is equipped with an improved air conditioning system, adjustable wrist rests and a suspension seat to help keep you working comfortably all day long.

EASY TO OPERATE

- Controls are easy to use and the intuitive Next Generation Monitor provides customizable machine operator preferences and easy to read machine information.

STICK STEER TRAVEL MODE

- Moving around the job site is even easier with the Cat Stick Steer option. Easily switch from traditional travel controls with levers and pedals to joystick controls with a push of a button. The benefit of less effort and improved control is in your hands!

BIG PERFORMANCE IN A MINI DESIGN

- Increased lifting, swinging, travel and multi-functioning performance helps you get the job done more efficiently. Dig-to-blade and dozer blade float features allow for easy clean up.

SAFETY ON THE JOB SITE

- Your safety is our top priority. The Cat mini excavator is designed to help keep you safe on the job. A back-up camera, courtesy work lights and a fluorescent retractable seat belt with optional seat belt reminder system are just a few of the safety features we've built into the machine.

SIMPLE SERVICE FOR LESS DOWNTIME

- Maintenance is quick and easy on the Cat mini excavator. Routine check points are easy to access at ground level with grouped service points and robust service panels.

LOWER OPERATING COSTS

- Equipped with features such as auto idle, auto engine shutdown, and efficient hydraulics with a variable displacement pump, the Cat mini excavator was designed with reducing your operating costs in mind.

UNMATCHED DEALER SUPPORT

- Your Cat dealer is here to help you reach your business goals. From providing equipment solutions to operator training to service needs and beyond, your Cat dealer is ready to help.



310 Mini Hydraulic Excavator

CAT TECHNOLOGY

EASE OF USE FOR CAT MINI EXCAVATORS

Ease of Use assists operators in controlling the machine to simplify operation, improve accuracy and enhance overall productivity on the job site. Ease of Use is available equipped on your mini excavator from the factory or as an upgrade kit post purchase.

Operators can choose from two software packages, Indicate or E-Fence to suit their application needs.

INDICATE

Ease of Use Indicate is an entry-level grade system providing visual and audible indicators to where the bucket is versus a target grade to cut and fill to exact specifications the first time without overcutting.

- Ideal for digging footings, septic systems, foundations, slope work and similar applications with level sites.
- Machine integrated depth measurement system from selected bench
- Operators can target a grade relative to the machine chassis (machine reference) or relative to gravity (earth reference).
- Operator can program a flat grade or a slope.
- Does not include the ability to automatically adjust stick, boom or bucket position. Cat Grade is required for autos functionality.
- Includes Swing Assist ideal for truck loading and trenching applications, and Bucket Assist ideal for sloping, leveling, fine grading and trenching applications.

E-FENCE

Ease of Use E-Fence automatically constrains machine motion within operator pre-set boundaries for Ceiling, Floor, Wall and Swing to avoid structures overhead, underground, in front or to the left or right of the machine.

- Ideal for applications near high-traffic, protecting structures on the job site, avoiding fiber optic cables and other underground utilities.
- Limits boom, stick, bucket, house and boom swing from operating beyond set boundaries.
- Includes Swing Assist ideal for truck loading and trenching applications, and Bucket Assist ideal for sloping, leveling, fine grading and trenching applications.

CAT GRADE

Cat Grade is available as an aftermarket-installed automatics system that is easy to learn and use. Cat Grade Advanced 2D and 3D give you the ability to create, manage and grade simple to complex designs with accuracy ensuring cuts and fills are made to exact specifications. Cat Grade reduces costs, improves accuracy, provides improved operator efficiency and enhances safety.

GRADE ADVANCED 2D

Cat Grade Advanced 2D allows the operator to set parameters for digging and leveling operations, including cross slope and work site main fall. Grade Advanced 2D also lets the operator input, edit and work to basic 2D design plans from the operator's seat.

- Ideal for commercial site pad designs, trenches, commercial septic systems and similar applications.
- Provides bucket position in real time, and the operator can select from a number of different viewing angles.

GRADE 3D

Cat Grade 3D for excavators adds deeper design capabilities, plus, Global navigation satellite system (GNSS) receivers and a correctional data source to achieve Real Time Kinematic (RTK) positioning guidance for more complex planes, slopes, contours and curves.

- Provides operator with bucket positioning in relation to preloaded 3D design files or background maps.
- Helps to coordinate multiple machine operations while maintaining accurate digging parameters across large job sites.

Availability varies by region, please contact our Cat dealer to discuss the best technology options for you and your application.

Specifications

Engine

Engine Model	Cat® C2.8 Turbo	
Net Power		
ISO 9249, 80/1269/EEC	51.2 kW	69.0 hp
Engine Power		
ISO 14396	55.4 kW	74.3 hp
Bore	90 mm	3.5 in
Stroke	110 mm	4.3 in
Displacement	2.8 L	171 in ³

- Meets U.S. EPA Tier 4 Final and EU Stage V emissions standards.
- Advertised power is tested per the specified standard in effect at the time of manufacture.
- Net power advertised is the power available at the flywheel when the engine is at the rated speed of 2,200 rpm and the engine is installed with the factory configured fan, air intake system, exhaust system and alternator with a minimum alternator load.

Weights

Minimum Operating Weight with Cab*	9536 kg	21,026 lb
Maximum Operating Weight with Cab**	10 367 kg	22,859 lb

*Minimum Weight is based on steel tracks, no counterweight, operator, full fuel tank, long stick, blade and no bucket.

**Maximum Weight is based on steel tracks with rubber pads, (500 kg/1,103 lb) counterweight, operator, full fuel tank, long stick, blade and no bucket.

Weight Increase from Minimum Configuration

Counterweight	250 kg	551 lb
Counterweight	500 kg	1,103 lb
Steel Tracks with Pads	330 kg	728 lb

Travel System

Travel Speed – High	4.7 km/h	2.9 mph
Travel Speed – Low	2.6 km/h	1.6 mph
Maximum Traction Force – High Speed	33 kN	7,419 lb
Maximum Traction Force – Low Speed	84.8 kN	19,064 lb
Ground Pressure – Minimum Weight	37.2 kPa	5.4 psi
Ground Pressure – Maximum Weight	40.2 kPa	5.8 psi
Gradeability (maximum)	30 degrees	

Service Refill Capacities

Cooling System	10.0 L	2.6 gal
Engine Oil	8.8 L	2.3 gal
Fuel Tank	145 L	38 gal
Hydraulic Tank	53 L	14 gal
Hydraulic System	140 L	37 gal

Hydraulic System

Load Sensing Hydraulics with Variable Displacement Piston Pump		
Pump Flow @ 2,400 rpm	233 L/min	62 gal/min
Operating Pressure – Equipment	285 bar	4,134 psi
Operating Pressure – Travel	285 bar	4,134 psi
Operating Pressure – Swing	230 bar	3,336 psi
Maximum Auxiliary Circuit – Primary		
Flow at Pump*	131 L/min	35 gal/min
Pressure at Pump*	285 bar	4,134 psi
Maximum Auxiliary Circuit – Secondary		
Flow at Pump*	33 L/min	9 gal/min
Pressure at Pump*	285 bar	4,134 psi
Digging Force – Stick	49.2 kN	11,060 lb
Digging Force – Bucket	77.7 kN	17,459 lb

*Flow and pressure are not combinable. Under load, as flow rises pressure goes down.

Swing System

Machine Swing Speed	10.0 rpm
---------------------	----------

Blade

Width (Standard)	2470 mm	97.2 in
Width (Wide)	2640 mm	103.9 in
Height	431 mm	17.0 in

Certification – Cab

Roll Over Protective Structure (ROPS)	ISO 12117-2:2008
Top Guard	ISO 10262:1998 (Level I)

310 Mini Hydraulic Excavator

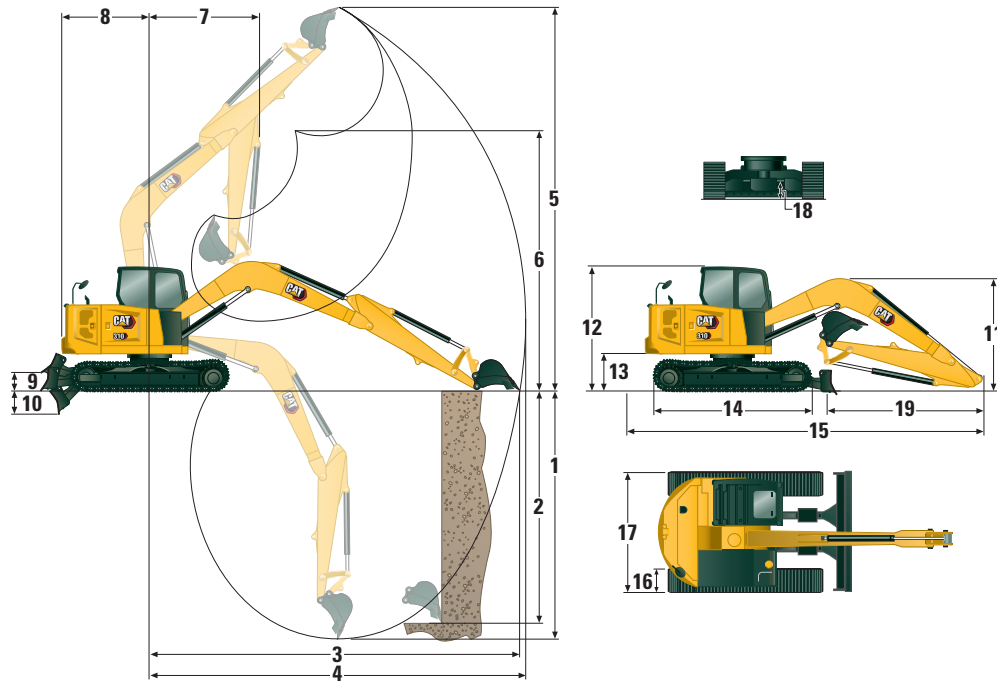

Dimensions

1 Dig Depth	5211 mm	205.2 in
2 Vertical Wall	4385 mm	172.6 in
3 Maximum Reach at Ground Level	7570 mm	298.0 in
4 Maximum Reach	7695 mm	303.0 in
5 Maximum Dig Height	7970 mm	313.8 in
6 Maximum Dump Clearance	5829 mm	229.5 in
7 Boom in Reach	2116 mm	83.3 in
8 Tail Swing		
with Counterweight (250 kg/551 lb)	1933 mm	76.1 in
with Counterweight (500 kg/1,103 lb)	1974 mm	77.7 in
without Counterweight	1800 mm	70.9 in
9 Maximum Blade Height	421 mm	16.6 in
10 Maximum Blade Depth	478 mm	18.8 in
11 Boom Height in Shipping Position		
Boom Transport – No Tools*	2550 mm	100.4 in
Boom Working – With Tools**	2700 mm	106.3 in
12 Cab Height	2541 mm	100.0 in
13 Swing Bearing Height	735 mm	28.9 in
14 Overall Undercarriage Length	3200 mm	126.0 in
15 Overall Shipping Length		
with Counterweight (250 kg/551 lb)	6983 mm	274.9 in
with Counterweight (500 kg/1,103 lb)	7024 mm	276.5 in
without Counterweight	6850 mm	269.7 in
16 Track Belt/Shoe Width	450 mm	17.7 in
17 Overall Track Width	2470 mm	97.2 in
18 Ground Clearance	356 mm	14.0 in
19 Stick Length	2500 mm	98.4 in

*Boom Height when stick is pinned in transport position (if available) with no attachments.

**Boom Height when stick is pinned in working position with attachments.

Lift Capacities – Minimum Configuration¹

Lift Point Height			Lift Point Radius 3 m (9.8 ft)			Lift Point Radius 4.5 m (14.8 ft)			Lift Point Radius (Maximum)			
			Over Front		Over Side	Over Front		Over Side	Over Front		Over Side	m (ft)
			Blade Down	Blade Up		Blade Down	Blade Up		Blade Down	Blade Up		
4.5 m (14.8 ft)	Long Stick	kg (lb)				2677* (5,903*)	2677* (5,903*)	2677* (5,903*)	1527* (3,367*)	1527* (3,367*)	1527* (3,367*)	5.81 (19.1)
3 m (9.8 ft)	Long Stick	kg (lb)	3998* (8,816*)	3998* (8,816*)	3998* (8,816*)	2989* (6,591*)	2989* (6,591*)	2438 (5,376)	1514* (3,338*)	1514* (3,338*)	1514* (3,338*)	6.39 (21)
1.5 m (4.9 ft)	Long Stick	kg (lb)	5147* (11,349*)	5147* (11,349*)	4192 (9,243)	3381* (7,455*)	2796 (6,165)	2261 (4,986)	1601* (3,530*)	1601* (3,530*)	1248 (2,752)	6.59 (21.6)
0 m (0 ft)	Long Stick	kg (lb)	5431* (11,975*)	5431* (11,975*)	3876 (8,547)	3548* (7,823*)	2643 (5,828)	2118 (4,670)	1812* (3,995*)	1545 (3,407)	1258 (2,774)	6.43 (21.1)

¹Minimum Weight includes steel tracks, no counterweight, operator, full fuel tank, long stick, blade and no bucket.

Lift Capacities – Maximum Configuration²

Lift Point Height			Lift Point Radius 3 m (9.8 ft)			Lift Point Radius 4.5 m (14.8 ft)			Lift Point Radius (Maximum)			
			Over Front		Over Side	Over Front		Over Side	Over Front		Over Side	m (ft)
			Blade Down	Blade Up		Blade Down	Blade Up		Blade Down	Blade Up		
4.5 m (14.8 ft)	Long Stick	kg (lb)				2677* (5,903*)	2677* (5,903*)	2677* (5,903*)	1527* (3,367*)	1527* (3,367*)	1527* (3,367*)	5.81 (19.1)
3 m (9.8 ft)	Long Stick	kg (lb)	3998* (8,816*)	3998* (8,816*)	3998* (8,816*)	2989* (6,591*)	2989* (6,591*)	2989* (6,591*)	1514* (3,338*)	1514* (3,338*)	1514* (3,338*)	6.39 (21)
1.5 m (4.9 ft)	Long Stick	kg (lb)	5147* (11,349*)	5147* (11,349*)	5147* (11,349*)	3381* (7,455*)	3381* (7,455*)	2652 (5,848)	1601* (3,530*)	1601* (3,530*)	1601* (3,530*)	6.59 (21.6)
0 m (0 ft)	Long Stick	kg (lb)	5431* (11,975*)	5431* (11,975*)	4571 (10,079)	3548* (7,823*)	3548* (7,823*)	2510 (5,535)	1812* (3,995*)	1812* (3,995*)	1508 (3,325)	6.43 (21.1)

²Maximum Weight includes steel tracks with rubber pads, counterweight (500 kg/1,103 lb), operator, full fuel tank, long stick, blade and no bucket.

*The above loads are in compliance with hydraulic excavator lift capacity rating standard ISO 10567:2007 and they do not exceed 87% of hydraulic lifting capacity or 75% of tipping capacity. The excavator bucket weight is not included on this chart. Lifting capacities are for long stick.

310 Environmental Declaration

The following information applies to the machine at the time of final manufacture as configured for sale in the regions covered in this document. The content of this declaration is valid as of the date issued; however, content related to machine features and specifications are subject to change without notice. For additional information, please see the machine's Operation and Maintenance Manual.

For more information on sustainability in action and our progress, please visit <https://www.caterpillar.com/en/company/sustainability>.

Engine

- The Cat® C2.8 Turbo engine meets U.S. EPA Tier 4 Final and EU Stage V emission standards.
- Cat diesel engines are required to use ULSD (ultra-low sulfur diesel fuel with 15 ppm of sulfur or less) or ULSD blended with the following lower-carbon intensity fuels** up to:
 - ✓ 20% biodiesel FAME (fatty acid methyl ester)*
 - ✓ 100% renewable diesel, HVO (hydrogenated vegetable oil) and GTL (gas-to-liquid) fuels
 Refer to guidelines for successful application. Please consult your Cat dealer or "Caterpillar Machine Fluids Recommendations" (SEBU6250) for details.

**Engines with no aftertreatment devices can use higher blends, up to 100% biodiesel (for use of blends higher than 20% biodiesel, consult your Cat dealer).*

***Tailpipe greenhouse gas emissions from lower-carbon intensity fuels are essentially the same as traditional fuels.*

Air Conditioning System

- The air conditioning system on this machine contains the fluorinated greenhouse gas refrigerant R134a (Global Warming Potential = 1430). The system contains 1.0 kg (2.20 lb) of refrigerant which has a CO₂ equivalent of 1.430 metric tonnes (1.576 tons).

Paint

- Based on best available knowledge, the maximum allowable concentration, measured in parts per million (PPM), of the following heavy metals in paint are:
 - Barium < 0.01%
 - Cadmium < 0.01%
 - Chromium < 0.01%
 - Lead < 0.01%

Sound Performance

Operator Sound Pressure 72 dB(A) (ISO 6396:2008)*
 Exterior Sound Power Level 99 dB(A) (ISO 6395:2008)**

- *The declared dynamic operator sound pressure levels per ISO 6396:2008. The measurements were conducted with the cab doors and windows closed.
- **The labeled sound power level for the CE marked configurations when measured according to the test procedure and conditions specified in 2000/14/EC.

Oils and Fluids

- Caterpillar factory fills with ethylene glycol coolants. Cat Diesel Engine Antifreeze/Coolant (DEAC) and Cat Extended Life Coolant (ELC) can be recycled. Consult your Cat dealer for more information.
- Cat Bio HYDO Advanced is an EU Ecolabel approved biodegradable hydraulic oil.
- Additional fluids are likely to be present, please consult the Operations and Maintenance Manual or the Application and Installation guide for complete fluid recommendations and maintenance intervals.

Features and Technology

- The following features and technology may contribute to fuel savings and/or carbon reduction. Features may vary. Consult your Cat dealer for details.
 - Advanced hydraulic systems balance power and efficiency
 - Power On Demand provides full time efficiency and power when you need it, and is transparent to the operator
 - Auto idle and auto engine shutdown
 - Extended maintenance intervals reduce fluid and filter consumption
 - Remote Flash and Remote Troubleshoot (if equipped)
 - Mini Hydraulic Excavator Ease of Use features improve operator efficiency minimizing fuel consumption (if equipped)
 - Cat Grade Advanced 2D and 3D improves operator efficiency minimizing fuel consumption (if equipped)

Recycling

- The materials included in machines are categorized as below with approximate weight percentage. Because of variations of product configurations, the following values in the table may vary.

Material Type	Weight Percentage
Steel	65.52%
Iron	21.19%
Rubber	3.50%
Mixed Metal	2.20%
Other	1.89%
Nonferrous Metal	1.81%
Plastic	1.55%
Fluid	1.47%
Mixed-Metal and Nonmetal	0.85%
Mixed Nonmetallic	0.01%
Uncategorized	0.00%
Total	100.00%

- A machine with higher recyclability rate will ensure more efficient usage of valuable natural resources and enhance End-of-Life value of the product. According to ISO 16714 (Earth-moving machinery – Recyclability and recoverability – Terminology and calculation method), recyclability rate is defined as percentage by mass (mass fraction in percent) of the new machine potentially able to be recycled, reused or both.

All parts in the bill of material are first evaluated by component type based on a list of components defined by the ISO 16714 and Japan CEMA (Construction Equipment Manufacturers Association) standards. Remaining parts are further evaluated for recyclability based on material type.

Because of variations of product configurations, the following values in the table may vary.

Recyclability – 96%

The data provided above was based on the product configuration as provided by the individual product group.

Standard and Optional Equipment

Standard and optional equipment may vary. Consult your Cat dealer for details.

	Standard	Optional		Standard	Optional
ENGINE			OPERATOR ENVIRONMENT (continued)		
Cat C2.8 Turbo Diesel Engine (U.S. EPA Tier 4 Final/EU Stage V) – Electronic Engine, Turbo, Fit-For-Life Diesel Particulate Filter (DPF) and Diesel Oxidation Catalyst (DOC) Aftertreatment System	✓		LED Interior Light	✓	
Automatic Engine Idle	✓		Literature Holder	✓	
Automatic Engine Shutdown	✓		Mounting Bosses for Top and Front Guards	✓	
Automatic Swing Brake	✓		12V Power Socket	✓	
Automatic Two Speed Travel	✓		Radio – Bluetooth, Auxiliary, Microphone, USB (charging only)	✓	
Fuel Water Separator with Indicator	✓		Skylight	✓	
Radial Seal – Double Element Air Filter	✓		Signaling/Warning Horn	✓	
Extended Life Coolant, –37° C (–37° F)	✓		Cab and (left side) Boom Work Lights	✓	
HYDRAULICS			Utility Space for Mobile Phone	✓	
Electronic Variable Displacement Piston Pump	✓		Rain Visor		✓
Load Sensing/Flow Sharing Hydraulics	✓		Next Generation Color LCD Monitor (IP66)	✓	
Power On Demand	✓		– Jog Dial Interface		
Hydraulic Temperature Monitoring	✓		– Fuel Level and Coolant Temperature Gauges		
Certified Accumulator	✓		– Maintenance and Machine Monitoring		
HYDO™ Advanced Hydraulic Oil	✓		– Performance and Machine Adjustments		
Third Auxiliary		✓	– Numeric Security Code		
OPERATOR ENVIRONMENT			– Multiple Languages		
TOPS – ISO 12117:1997	✓		– Camera Ready (IP68 and IP69K)		
ROPS ISO 12117-2:2008	✓		– Hour Meter with Wake Up Switch		
Stick Steer Mode	✓		Next Generation Advanced Monitor (below are all included with Next Generation Advanced Monitor option)		✓
Travel Cruise Control	✓		– Touch Screen		
Control Pattern Changer	✓		– Site Reference System		
Adjustable Wrist Rests	✓		– High Definition Camera Capable (IP68 and IP69K)		
Molded Footrests	✓		– Numeric Security Code		
Removable, Washable Floor Mat	✓		TECHNOLOGY (availability varies by region)		
Travel Pedals and Hand Levers	✓		Ease of Use Indicate		✓
Cat Key with Passcode Option	✓		Ease of Use E-Fence		✓
Push to Start with Bluetooth® Key		✓	Cat Grade Advanced 2D		✓
HVAC with Automatic Temperature Control	✓		Cat Grade 3D		✓
Hydraulic Lockout Controls	✓		Product Link™ Basic	✓	
Integrated Lower Front Window	✓		Product Link Elite (regulations apply)		✓
Assisted Front Window Overhead Storage	✓		<i>(continued on next page)</i>		
Rear Window Emergency Exit	✓				
Cab Mirrors (vary by region)	✓				
Fabric, High Back, Suspension Seat	✓				
Air Suspension Heated Seat		✓			
Retractable Seat Belt (75 mm/3 in)	✓				
Seat Belt Reminder System		✓			
Coat Hook	✓				
Cup Holder	✓				

310 Mini Hydraulic Excavator

Standard and Optional Equipment *(continued)*

Standard and optional equipment may vary. Consult your Cat dealer for details.

	Standard	Optional		Standard	Optional
UNDERCARRIAGE			ELECTRICAL		
Greased and Lubricated Track	✓		12 Volt Electrical System	✓	
Tie Down Eyes on Track Frame	✓		90 Ampere Alternator	✓	
Dozer Straight Blade	✓		900 CCA Maintenance Free Battery	✓	
Wide Dozer Blade		✓	Lock Out/Tag Out Battery Disconnect	✓	
Dozer Float	✓		Ignition Key Stop Switch	✓	
Bolt-on, Reversible Wear Edge	✓		Travel Alarm	✓	
Steel Tracks (450 mm/17.7 in wide)		✓	Rear and Side Camera	✓	
Wide Steel Tracks (600 mm/23.6 in)		✓	Rotating Beacon		✓
Steel Track with Rubber Pads		✓	GUARDING		
Track Guides		✓	ROPS ISO 12117-2:2008	✓	
BOOM, STICK AND LINKAGES			Top Guard ISO 10262:1998 (Level I)	✓	
One Piece Boom (4300 mm/169.3 in)	✓		Top Guard ISO 10262:1998 (Level II)		✓
Long Stick (2500 mm/98.4 in)	✓		Front Guard (Mesh) ISO 10262:1998 (Level I)		✓
Front Shovel Capable – Pin-on/Manual Coupler/Hydraulic Coupler for Cat Tools (not available in all regions)	✓		Front Guard (Heavy Duty) ISO 10262:1998 (Level II)		✓
Thumb Ready (not available in all regions)	✓		OTHER		
Attachments including Buckets, Augers and Hammers		✓	Counterweight (250 kg/551 lb)		✓
2nd Auxiliary Hydraulic Lines		✓	Counterweight (500 kg/1,103 lb)		✓
Boom Lowering Control Valve (Standard in Europe)		✓	Locks on External Enclosure Doors	✓	
Stick Lowering Control Valve (Standard in Europe)		✓	Lockable Fuel Cap	✓	
Certified Lifting Eye		✓	Beacon Socket	✓	
			Rear Reflectors	✓	
			Water Jacket Heater		✓
			Refueling Pump		✓

Zeppelin Baumaschinen GmbH
 Graf-Zeppelin-Platz 1 · 85748 Garching bei München
 Tel. 089 32000-0 · zeppelin-cat@zeppelin.com
 zeppelin-cat.de

Zeppelin Österreich GmbH
 Zeppelinstraße 2 · 2401 Fischamend bei Wien
 Tel. 02232 790-0 · info.at@zeppelin.com
 zeppelin-cat.at



For more complete information on Cat products, dealer services, and industry solutions, visit us on the web at www.cat.com

© 2025 Caterpillar
 All rights reserved

Materials and specifications are subject to change without notice. Featured machines in photos may include additional equipment. See your Cat dealer for available options.

CAT, CATERPILLAR, LET'S DO THE WORK, their respective logos, "Caterpillar Corporate Yellow," the "Power Edge" and Cat "Modern Hex" trade dress as well as corporate and product identity used herein, are trademarks of Caterpillar and may not be used without permission.

AEHQ8490-02 (03-2025)
 Replaces AEHQ8490-01
 Build Number: 08A
 (North America, Chile, Europe,
 Turkey, ANZP, South Korea)

